

# 35001 35mm平脚阀芯

## 35mm flat base cartridge

### 阀芯技术参数

#### Technical Characteristics of The Cartridge

开启角度：23°      旋转角度：90°      最高使用温度：90°C  
Max On/Off angel : 23°      Max Cold/Hot turning angel : 100°      Max temperature : 90°C

建议锁紧力矩：10~15Nm      冷热操作力矩：0.2~0.4Nm (任何水温)  
Tightness of hex nut torque : 10~15Nm      Cold / Hot operation torque : 0.2~0.4Nm (Under any water temp)

开关操作力矩：0.15~0.35Nm (任何水温)  
On/Off operation torque : 0.15~0.35Nm (Under any water temp)

阀芯破坏强度：≥12Nm  
Broken torque : ≥12Nm

爆破压：≥35bar  
Burst pressure : ≥35bar

3bar水压下流量值：≥24L/min  
Flow rate at 3bar : ≥24L/min

寿命测试：EN817:2008 280,000cycles  
ASME A 112.18.1-2008 2,000,000cycles  
Life cycle test : EN817:2008 280,000cycles  
ASME A 112.18.1-2008 2,000,000cycles

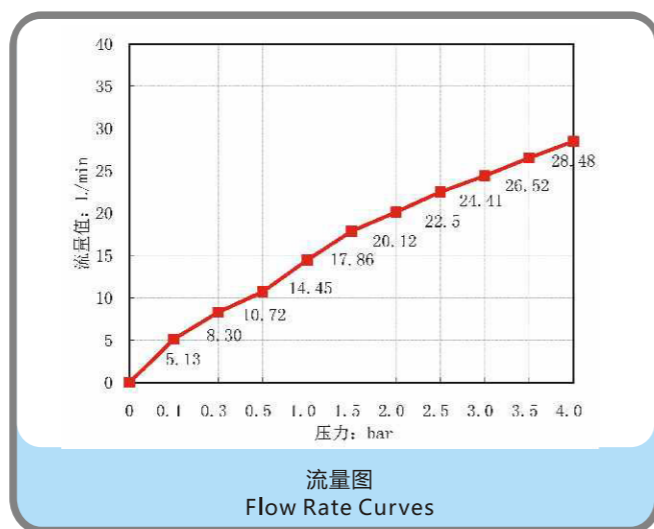

### 安装尺寸图

#### Drawings of Mounting Dimensions

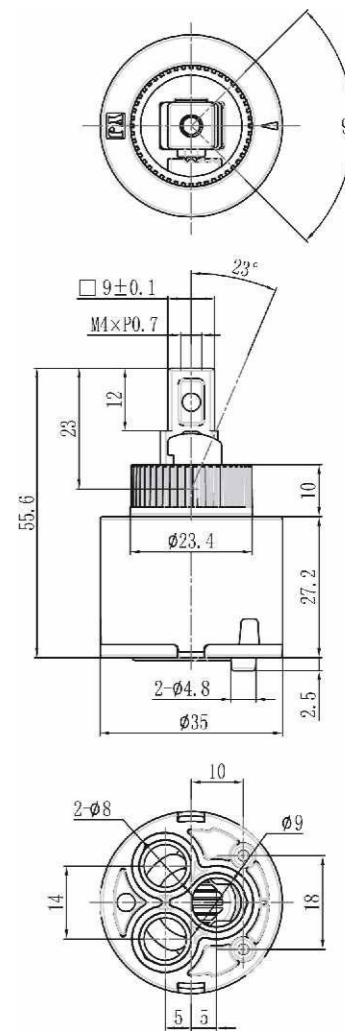
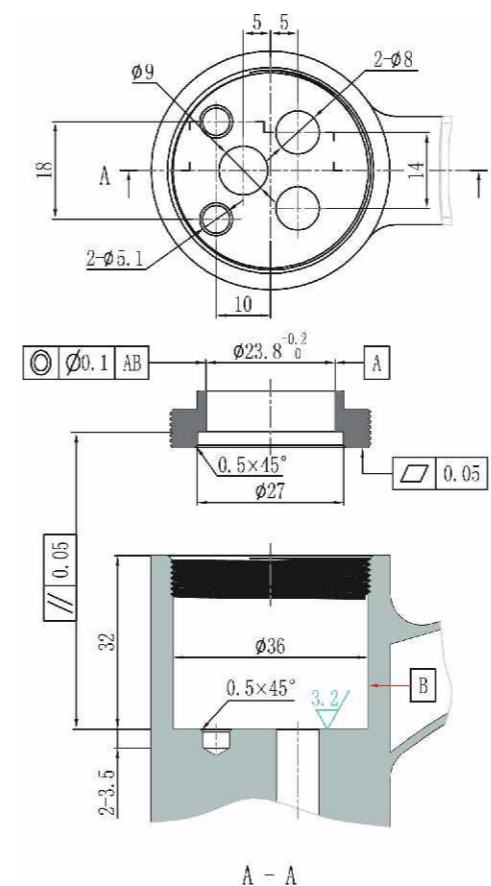

### 认证

#### Certification

